



## CARACTERÍSTICAS:

- Equilibrado.
- Multimuelle.
- Sentido rotación independiente.
- Conexión para lavado y quench.
- API 682 / ISO 21049.
- Categoría 2 y 3, Tipo A, Arreglo 1.

## LÍMITES OPERATIVOS:

$d_1 = 19,05 \div 110 \text{ mm}$      $p = 40 \text{ kg/cm}^2$

$v = 23 \text{ m/s}$              $t = -40 \div +220^\circ\text{C}$  (\*)

(\*) La resistencia a la temperatura está condicionada por el material de las juntas secundarias utilizadas.

Los límites operativos vienen condicionados por el factor PV, que está determinado tanto por las características del sistema de sellado como por las de la aplicación.

## DESCRIPCIÓN:

Cartucho simple con conexiones para realizar el lavado entre las caras de rozamiento y sistema Quench con fluido sin presurizar para refrigeración. Para aplicaciones donde se requiere trabajar a altas presiones. Las características especiales del cartucho le proporcionan gran robustez y fiabilidad. Su diseño permite un movimiento axial de hasta  $\pm 2.0 \text{ mm}$ , dependiendo del diámetro y el montaje.

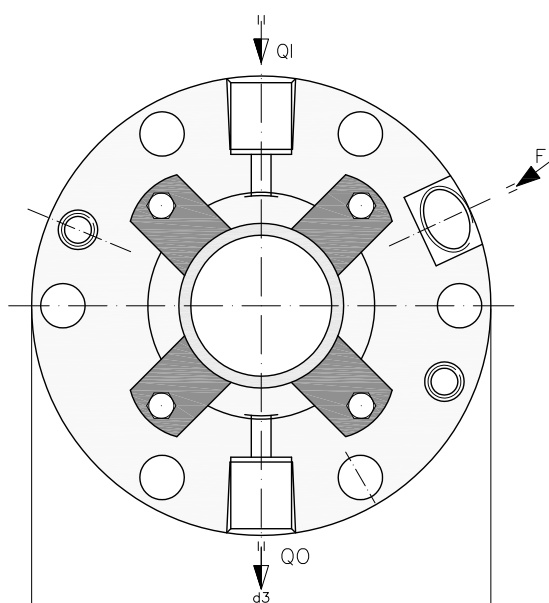

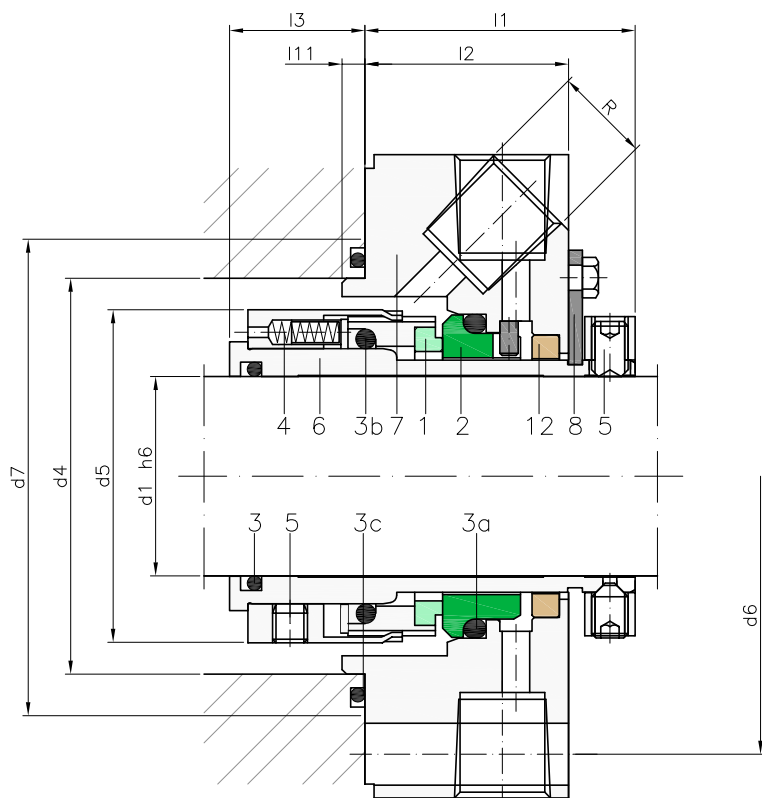

**COMPONENTES:**

- 1 Cara de roce rotante
- 2 Cara de roce fija
- 3 Juntas tóricas
- 4 Muelles
- 5 Tornillo de fijación
- 6 Camisa del cartucho
- 7 Brida
- 8 Clips de fijación
- 12 Anillo de PTFE para quench

**TABLA DIMENSIONAL**

Medidas en mm

Eje										
mm	d <sub>3</sub>	d <sub>4</sub>	d <sub>5</sub>	d <sub>6</sub>	d <sub>7</sub>	l <sub>1</sub>	l <sub>2</sub>	l <sub>3</sub>	l <sub>11</sub>	
20	138,0	70,0	50,0	105,0	85,0	94,0	76,0	1,0	6,0	
30	148,0	80,0	62,0	115,0	95,0	98,0	77,0	2,5	6,0	
40	158,0	90,0	72,0	125,0	105,0	98,5	77,5	7,0	6,0	
50	168,0	100,0	86,0	140,0	115,0	99,5	78,5	12,0	6,0	
60	188,0	120,0	99,0	160,0	135,0	102,0	81,0	18,5	6,0	
70	198,0	130,0	109,0	170,0	145,0	106,0	81,0	18,0	6,0	
80	208,0	140,0	119,0	180,0	155,0	106,0	81,0	23,0	6,0	
90	238,0	160,0	129,0	205,0	175,0	106,0	81,0	23,0	6,0	
100	248,0	170,0	153,0	215,0	185,0	109,0	81,0	24,0	6,0	
110	258,0	180,0	168,0	225,0	195,0	109,0	81,0	24,0	6,0	

Medidas en pulgadas

Eje											
(")	mm	d <sub>3</sub>	d <sub>4</sub>	d <sub>5</sub>	d <sub>6</sub>	d <sub>7</sub>	l <sub>1</sub>	l <sub>2</sub>	l <sub>3</sub>	l <sub>11</sub>	
0,750	19,05	138,0	70,0	50,0	105,0	85,0	94,0	76,0	1,0	6,0	
1,125	28,575	148,0	80,0	62,0	115,0	95,0	98,0	77,0	2,5	6,0	
1,500	38,10	158,0	90,0	72,0	125,0	105,0	98,5	77,5	7,0	6,0	
2,000	50,80	168,0	100,0	86,0	140,0	115,0	99,5	78,5	12,0	6,0	
2,250	57,15	188,0	120,0	99,0	160,0	135,0	102,0	81,0	18,5	6,0	
2,750	69,85	198,0	130,0	109,0	170,0	145,0	106,0	81,0	18,0	6,0	
3,125	79,38	208,0	140,0	119,0	180,0	155,0	106,0	81,0	23,0	6,0	
3,500	88,90	238,0	160,0	129,0	205,0	175,0	106,0	81,0	23,0	6,0	
3,750	95,25	248,0	170,0	153,0	215,0	185,0	109,0	81,0	24,0	6,0	
4,250	107,95	258,0	180,0	168,0	225,0	195,0	109,0	81,0	24,0	6,0	

Medidas sujetas a variaciones o modificaciones.